

Installation Instruction

For 6 foot / 1.8m Diameter Ultra-high Performance Antenna

Model ADxxG-6-T2 (13 to 23 GHz)

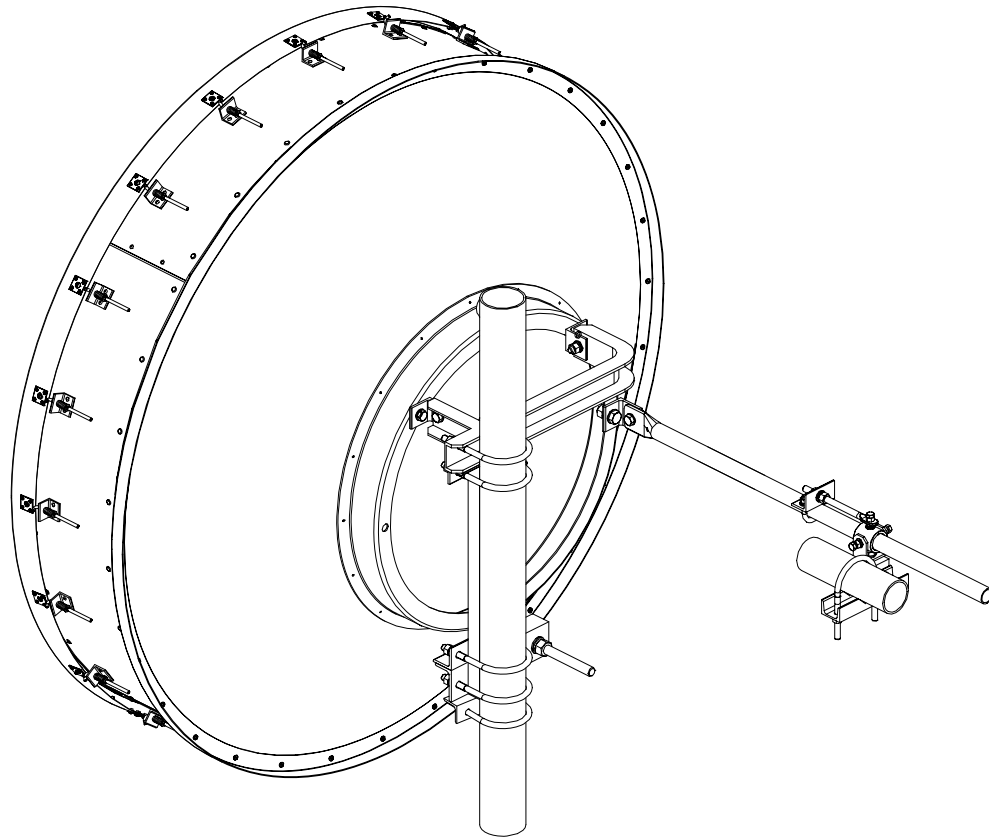

Before Installation, please read these instructions carefully.

- ◆ This instruction guide is for the installation of 6 foot / 1.8m Ultra-high performance microwave antenna.
- ◆ Installation, maintenance and removal of antenna should be carried out by qualified, experienced personnel.
- ◆ To guarantee performance, the antenna should be inspected once a year by qualified personnel

CONTENTS

1. Requirement of Installation	1
1.1 Mounting Pole	1
1.2 Tools Required for Installation	1
1.3 Torque Parameters of Fasteners	1
2. Open the Package and Identify Parts	1
3. Mount Radome	2
4. Mount Reflector Assembly	3
5. Mount Feeder	3
6. Mount Transition Section	4
7. Mount Hanging Bracket.....	4
8. Mount Anti-skid Bracket.....	5
9. Mounting to the Pole	5
10. Mount Sway Bar.....	6
11. Antenna Installation.....	6
12. Antenna Adjustment	7
13. Mechanical Dimensions	8

1. Requirement of Installation

1.1 Mounting Pole

Microwave antenna must be fixed to the Mounting Pole of 114 mm Diameter.

1.2 Tools Required for Installation

20×200 Adjustable Spanner (Used for bolt M12-M16)

10mm Open-end Spanners (Used for bolt M6)

17-19 mm Open-end Spanners (Used for bolt M12)

3mm L-Spanner (Used for Bolt M4)

Cross Screw-driver (Used for Bolt M6)

Torque Spanner (Recommended)

Pliers

1.3 Torque Parameters of Fasteners

Customer can use these torque parameters as reference to assembly the antenna.

Table of Torque Parameters

NO.	Fastener Size	Torque (N·m)
1	M4	1.3
2	M5	3
3	M6	5
4	M10	28
5	M12	58
6	M14	92
7	M16	112
8	M24	200

2. Open the Package and Identify Parts

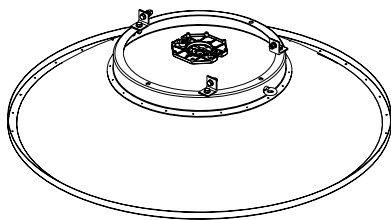

Reflector Assembly (1 set)

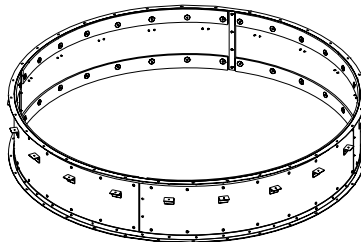

Shroud Assembly (1 set)

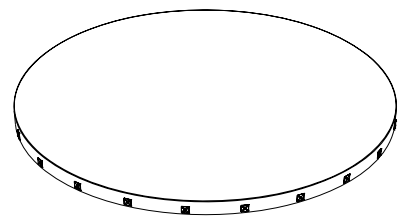

Radome (1 pc)

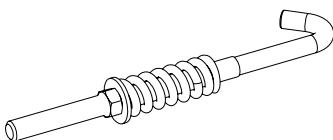

Hook (20 pcs)

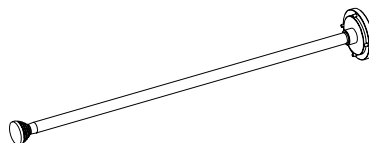

Feeder (1 set)

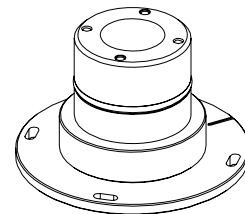

Transition Section (1 set)

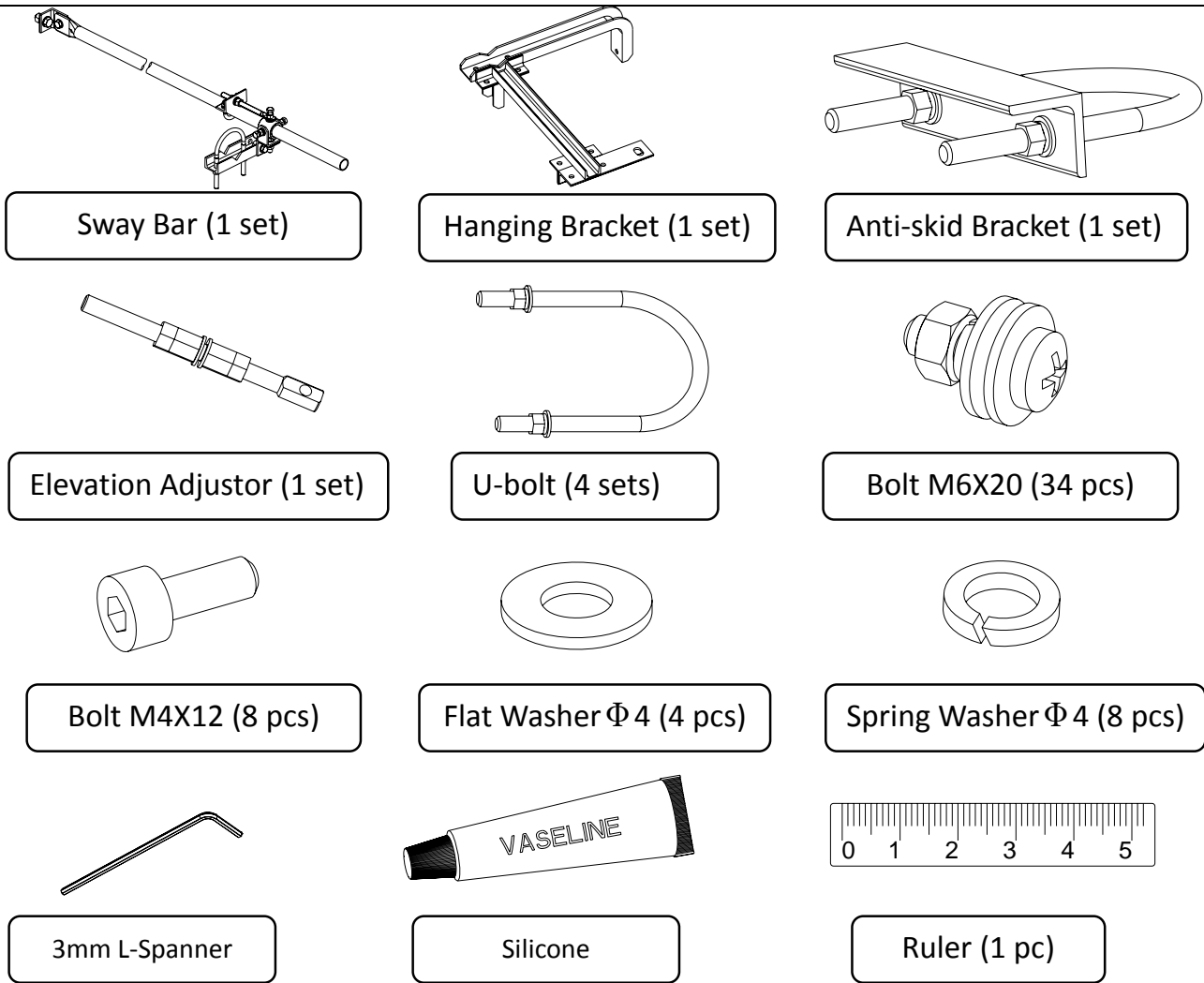
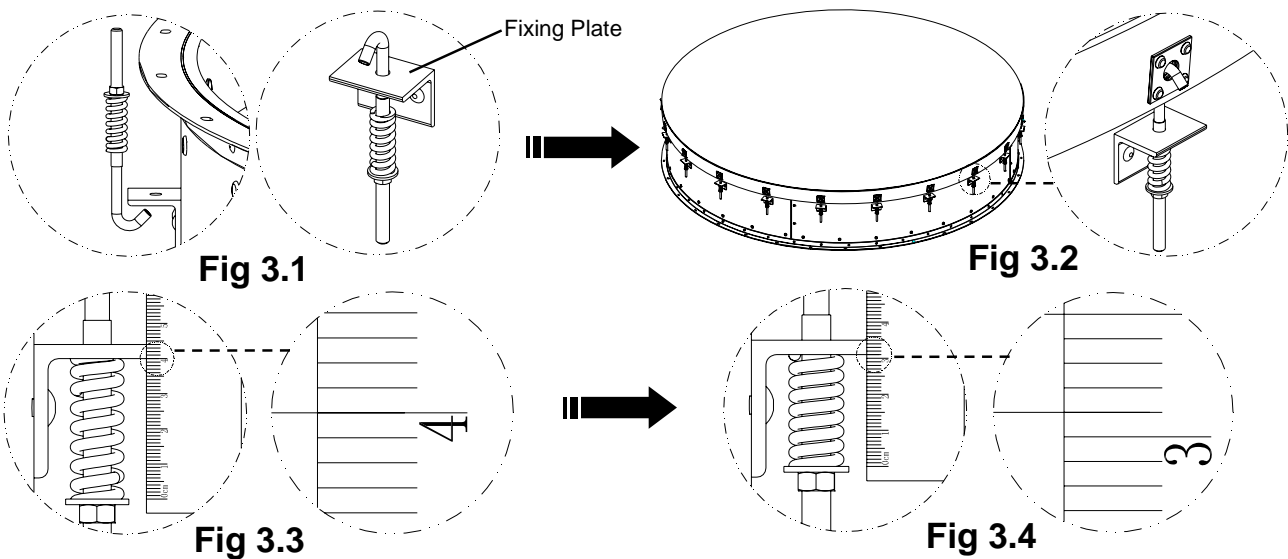

Fig 2.1 Parts List

3. Mount Radome



3.1 Put hooks (20 pcs) in the hole of Fixing Plate (shown in Fig3.1).

3.2 Hitch hooks (20 pcs) to the radome (shown in Fig3.2), and then tighten nuts of hooks,

until spring length is 40mm to 31mm (shown in Fig3.3 & Fig 3.4).

4. Mount Reflector Assembly

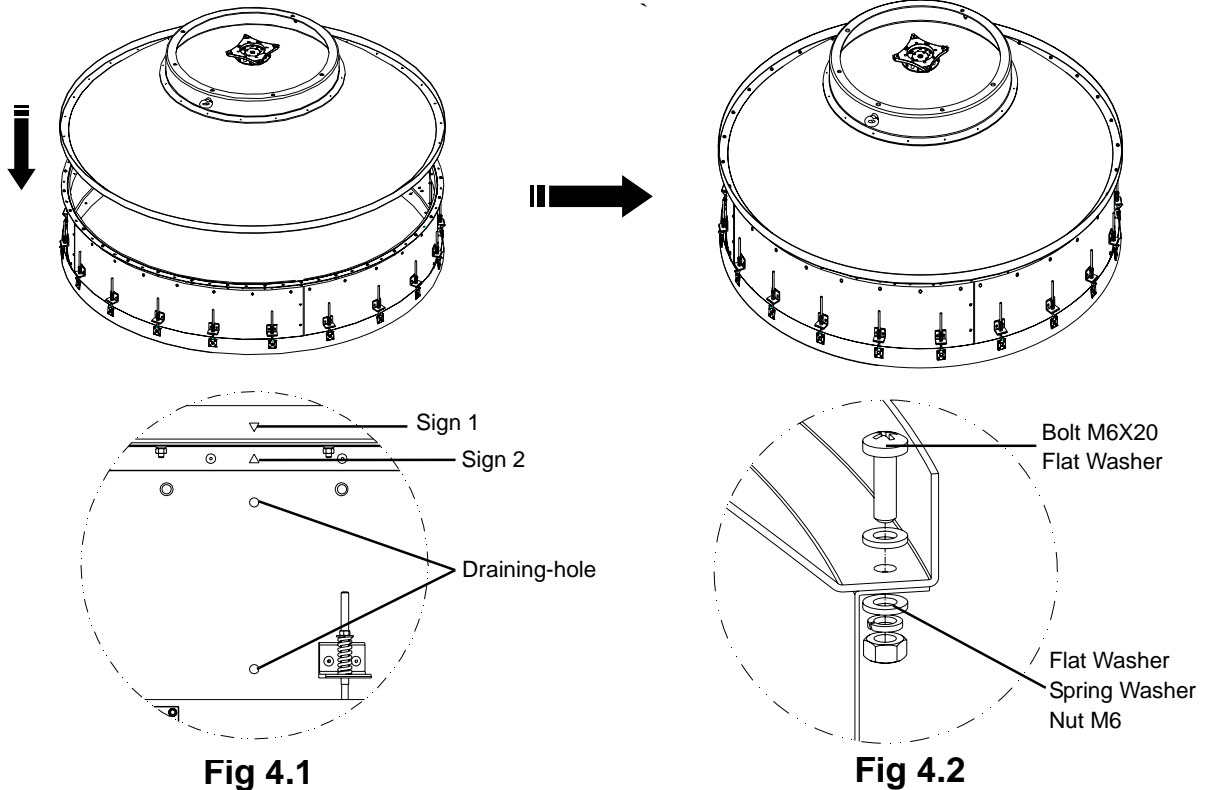

4.1 Turn the Reflector Assembly over, and then fit it on the Shroud Assembly with Sign 1 and Sign 2 aligned (shown in Fig 4.1).

4.2 Use M6X20 Bolt, Flat Washer, Spring Washer and Nut (32pcs) to connect Reflector Assembly with Shroud Assembly (shown in Fig 4.2).

4.3 Tighten all the standard parts.

5. Mount Feeder

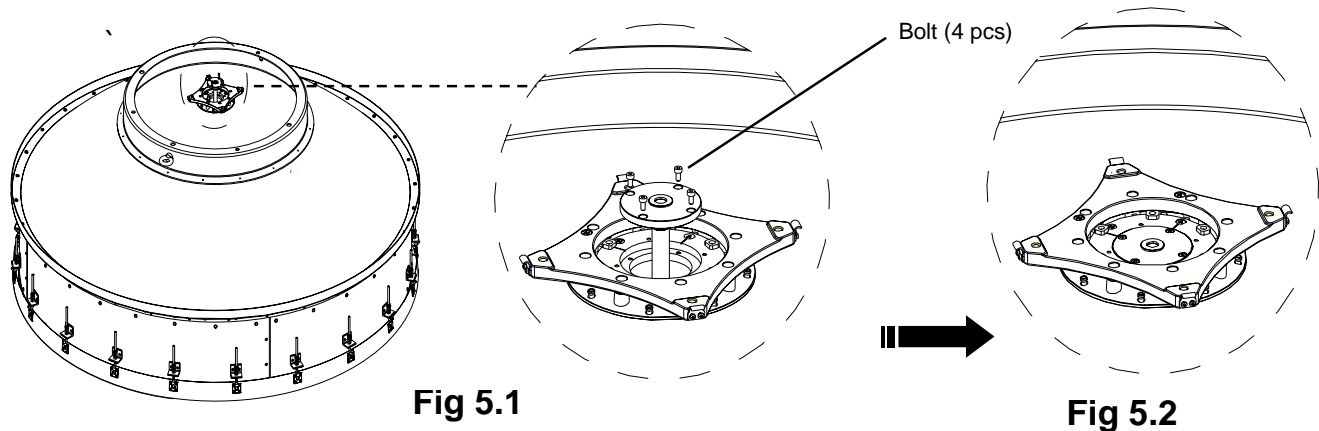

5.1 Put Feeder into the Center Plate, and then tighten bolts (shown in Fig 5.1 & Fig 5.2).

6. Mount Transition Section

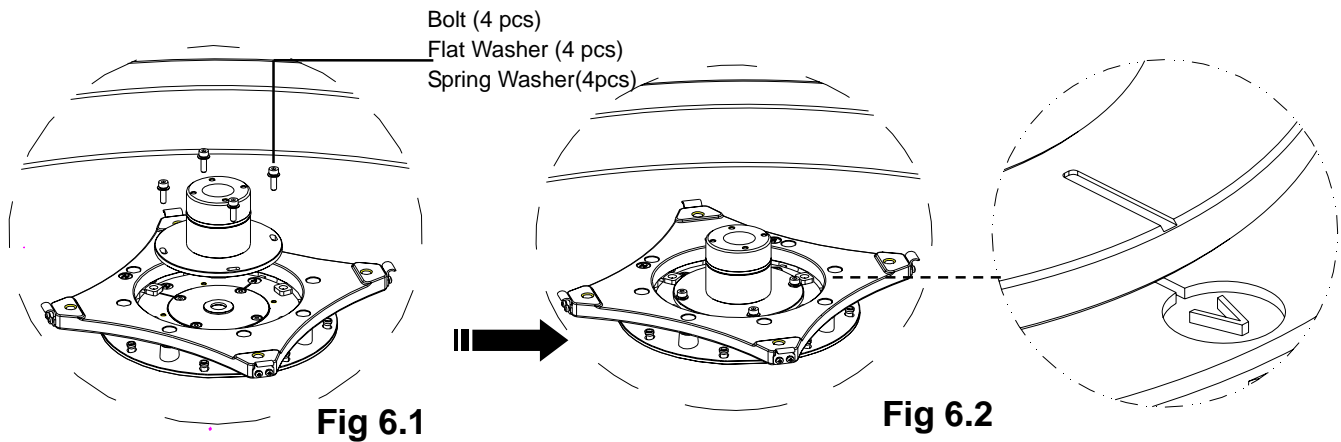

6.1 Put Transition Section into the Center Plate, and make sure it is in the vertical polarization (shown in Fig 6.2).

6.2 Use bolt (4 pcs) to connect these two parts (shown in Fig 6.1).

6.3 Tighten all the standard parts (shown in Fig 6.2).

7. Mount Hanging Bracket

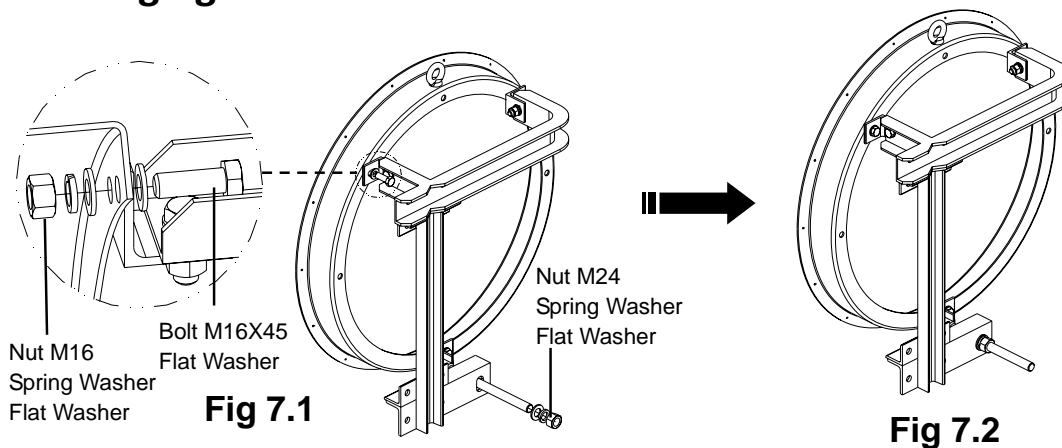

7.1 Put Hanging Bracket into the Back Ring, and then use M16X45 bolt (3 pcs) and M24 Nut to connect these two parts (shown in Fig 7.1).

7.2 Tighten all the standard parts (shown in Fig 7.2).

8. Mount Anti-skid Bracket

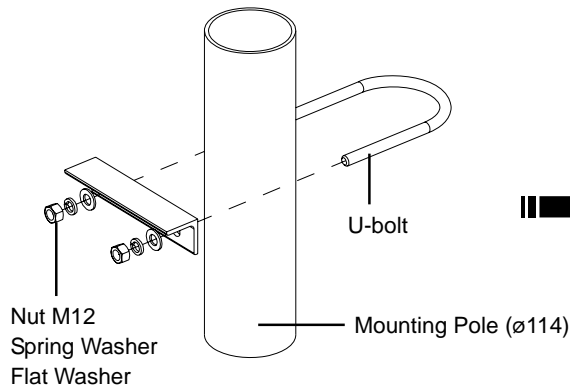

Fig 8.1

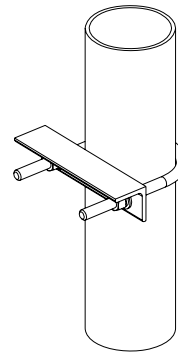

Fig 8.2

8.1 Fix Anti-skid Bracket to the Mounting Pole (shown in Fig 8.1).

8.2 Tighten all the standard parts (shown in Fig 8.2).

9. Mounting to the Pole

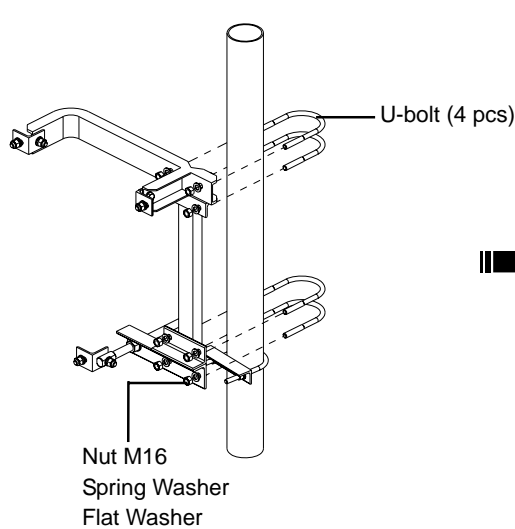

Fig 9.1

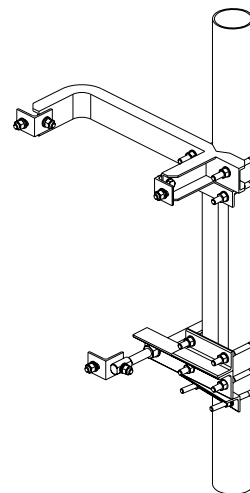
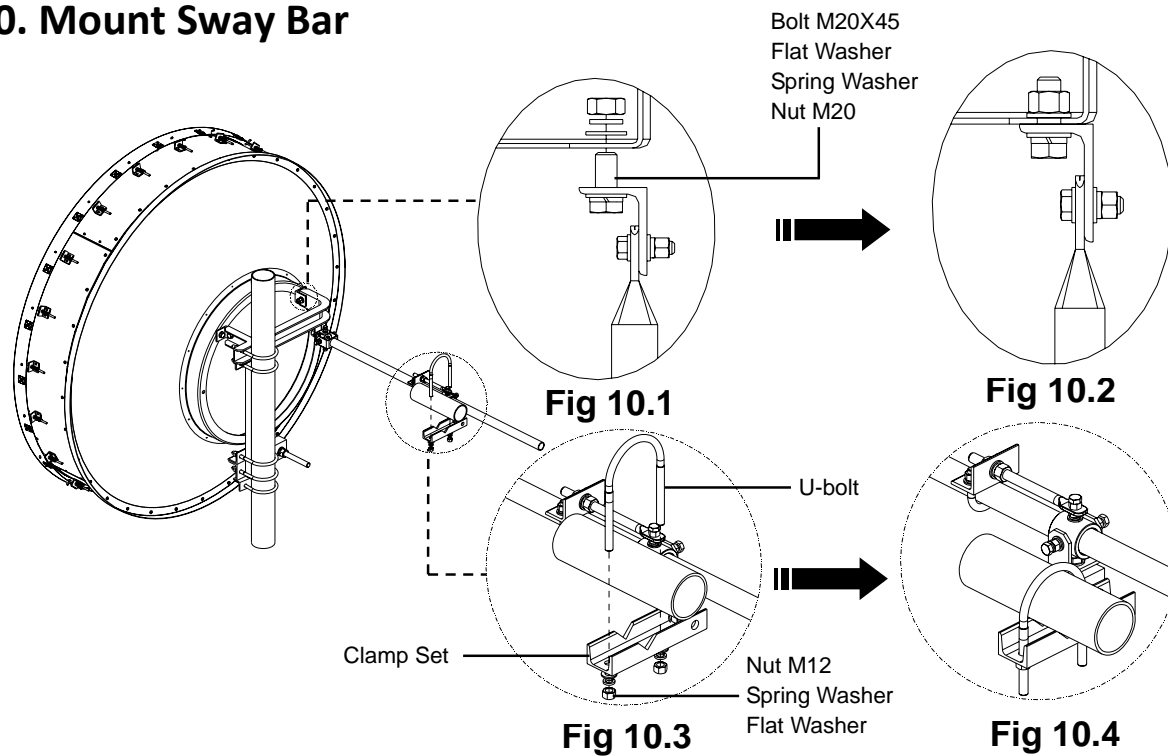

Fig 9.2

9.1 Mount antenna to the pole by 4 U-bolts (shown in Fig 9.1).

9.2 Tighten all the standard parts (shown in Fig 9.2).

10. Mount Sway Bar



10.1 Use M20X45 bolt to connect Sway Bar with antenna's Back Ring (shown in Fig 10.1).

10.2 Fix Clamp Set to the tower.

10.3 Tighten all the standard parts (shown in Fig 10.2 & Fig 10.4).

11. Antenna Installation

The antenna can be installed either on the left hand or right hand side of the pole (shown in Fig 11.1). After installation, make sure bottom draining-hole open.

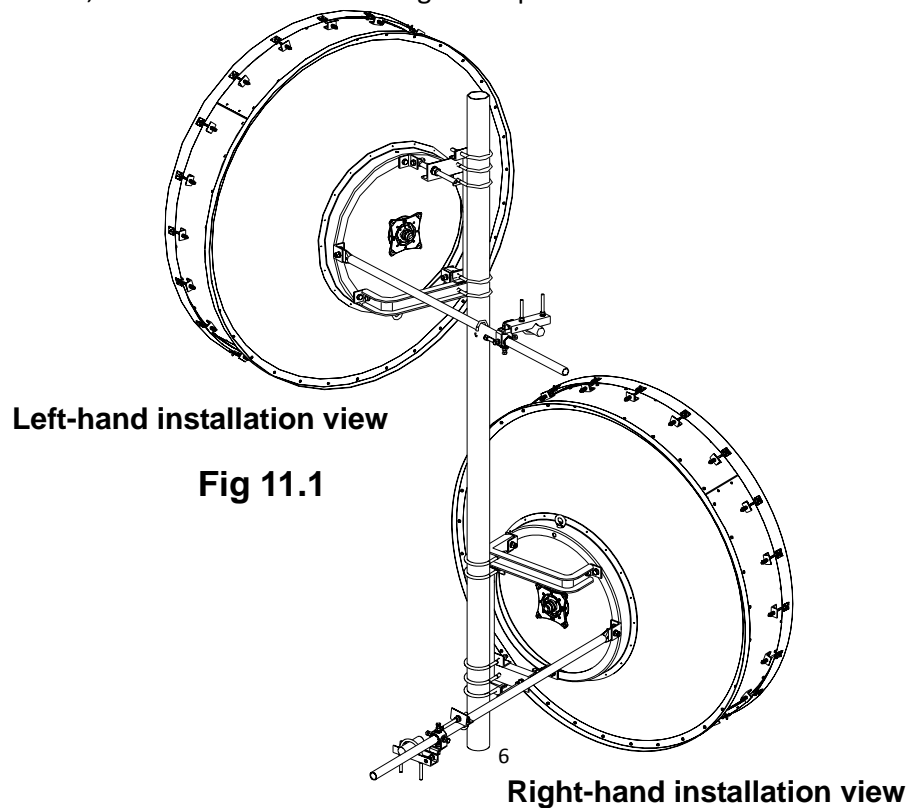

12. Antenna Adjustment

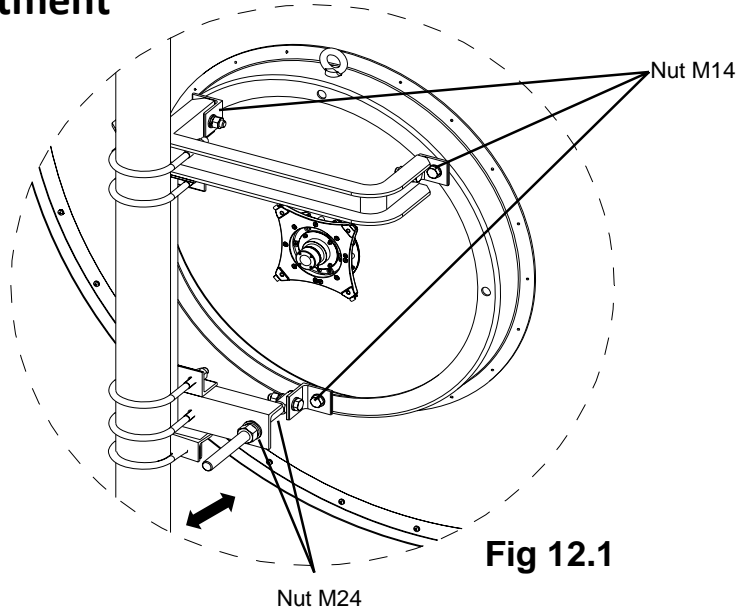

Fig 12.1

12.1 Elevation Adjustment

- ① Loosen the M14 Nut and bolt (shown in Fig 12.1), then slowly rotate M24 Nut clockwise or counterclockwise to make elevation adjustment.
- ② The antenna fine elevation adjustment range is from -5° to $+5^{\circ}$.
- ③ Tighten all the standard parts.

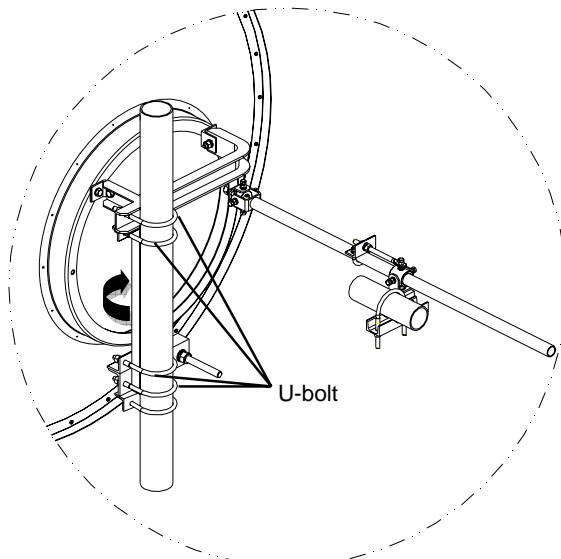

Fig 12.2

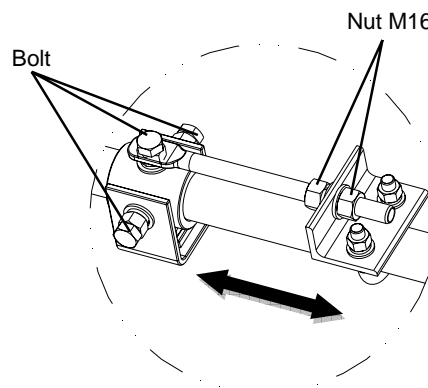
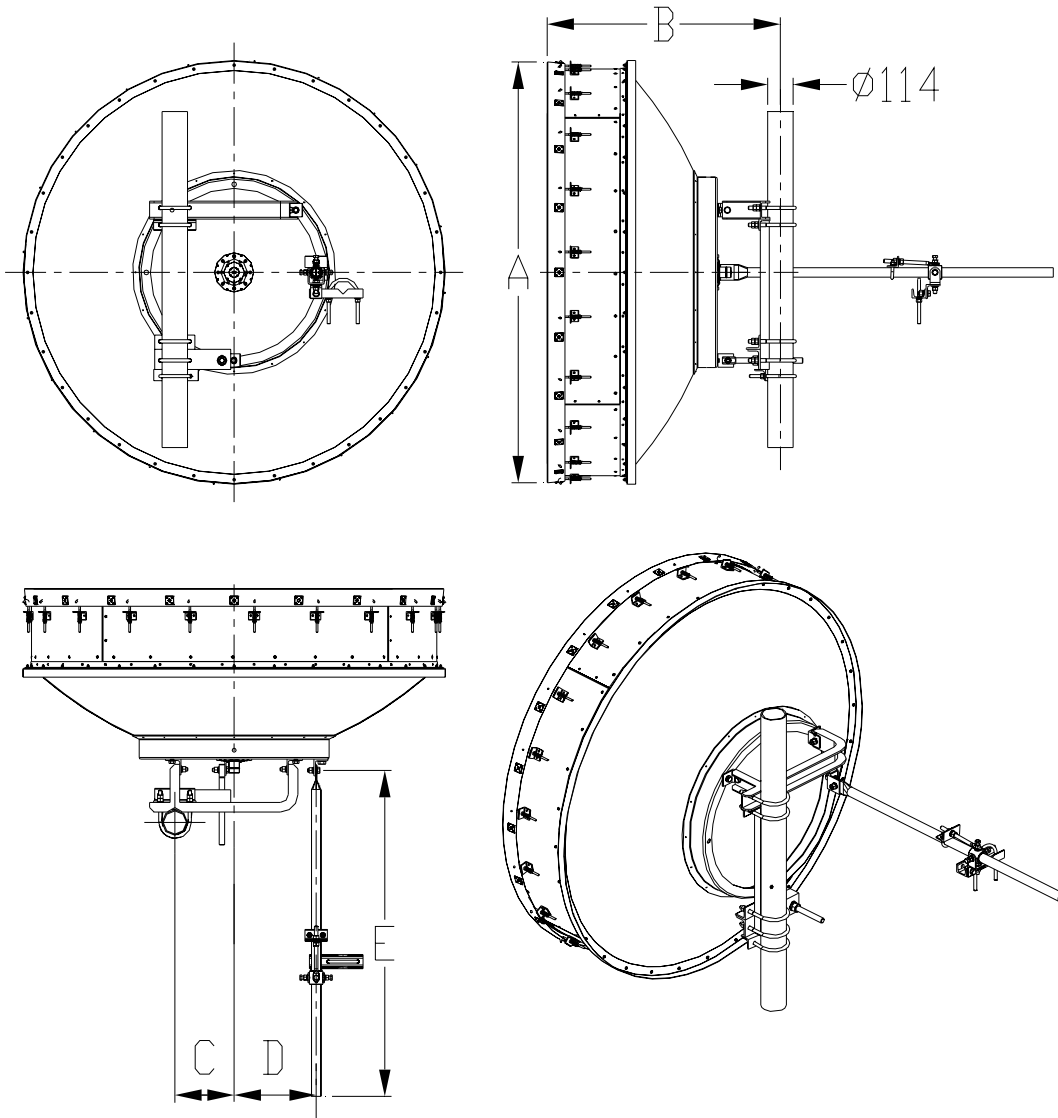

Fig 12.3

12.2 Azimuth Adjustment

- ① Loosen nut of U-bolt (shown in Fig 12.2), and then rotate M16 Nut clockwise or counterclockwise to make azimuth adjustment (shown in Fig 12.3).
- ② The antenna fine azimuth adjustment range is from -5° to $+5^{\circ}$.
- ③ Tighten all the fasteners.

13. Mechanical Dimensions



Dimensions (in/mm)	
A	73.6 / 1877
B	41.1 / 1044
C	10.43 / 265
D	14.45 / 367
E	76.97 / 1955